

# TORSION SPRINGS

## Guide to using tables

### Radius

please note that R (radius) where force is applied, is always 1/2 of A (length of leg).  
Dotted lines of legs show loaded position where values of T (Torque) will be achieved at R (Radius)

### Length of Leg

lengths of leg are shown on A in the sketches below.

### Outside Diameter

of spring body.

### Suggested Mandrel

size allows approximately a 10% clearance for the various deflections shown in examples below. If greater deflections are required, we suggest a suitable reduction in mandrel size.

### Lee Stock Number

Please add suffix **M** for Music Wire or **S** for 302 Stainless Steel when ordering.

### Wire Diameter

in ascending order of size.

### Torque

values shown are for average use. However, if properly mounted and the values shown under T (Torque) are reduced by approximately 20%, the life of the spring will be considerably improved (See note 6).

LEE STOCK NUMBER		NOMINAL WIRE DIAMETER		(T) TORQUE (see Footnotes)		(R) RADIUS		(A) LENGTH OF LEG		OUTSIDE DIAMETER		SUGGESTED MANDREL SIZE		(L) BODY LENGTH APPROX.		TOTAL NO. OF COILS	PRICE GROUP	
MM	IN	MM	IN	N-MM	IN-LB	MM	IN	MM	IN	MM	IN	MM	IN	MM	IN		Music Wire	Stainless Steel
LT 012A 01	0.30	0.012	5.65	0.050	4.75	0.187	9.52	0.375	2.67	0.105	1.65	0.065	1.37	0.054	3.0	F	M	K
LT 012A 07	0.36	0.014	8.47	0.075	6.35	0.250	12.70	0.500	3.72	0.146	2.36	0.093	0.99	0.039	2.25	H	K	K
LT 014A 01	0.36	0.014	8.47	0.075	6.35	0.250	12.70	0.500	3.15	0.124	1.57	0.062	1.65	0.065	3.25	F	H	K
LT 014A 07	0.36	0.014	8.47	0.075	6.35	0.250	12.70	0.500	4.37	0.172	3.18	0.125	1.16	0.046	2.25	H	K	K
LT 015B 01	0.38	0.015	11.30	0.100	6.35	0.250	12.70	0.500	2.82	0.111	1.57	0.062	1.73	0.068	3.25	H	K	K
LT 015B 07	0.38	0.015	11.30	0.100	6.35	0.250	12.70	0.500	4.35	0.171	2.36	0.093	1.24	0.049	2.25	H	K	M
LT 017C 01	0.43	0.017	14.12	0.125	6.35	0.250	12.70	0.500	4.06	0.160	2.36	0.093	1.96	0.077	3.25	F	K	K
LT 017C 07	0.43	0.017	14.12	0.125	9.53	0.375	19.05	0.750	5.67	0.223	3.96	0.156	1.40	0.055	2.25	H	K	K
LT 019C 01	0.46	0.018	16.95	0.150	6.35	0.250	12.70	0.500	4.52	0.178	2.77	0.109	2.03	0.080	3.25	H	K	K
LT 019C 07	0.46	0.018	16.95	0.150	9.53	0.375	19.05	0.750	5.94	0.234	3.96	0.156	1.49	0.059	2.25	H	K	M
LT 020D 01	0.51	0.020	22.60	0.200	9.52	0.375	19.05	0.750	4.85	0.191	3.05	0.120	2.29	0.090	3.25	H	K	K
LT 020D 07	0.51	0.020	22.60	0.200	12.70	0.500	25.40	1.000	6.78	0.267	4.78	0.188	1.65	0.065	2.25	H	K	M
LT 021D 01	0.53	0.021	28.25	0.250	9.52	0.375	19.05	0.750	5.08	0.200	3.05	0.120	2.41	0.095	3.25	H	K	K
LT 021D 07	0.53	0.021	28.25	0.250	12.70	0.500	25.40	1.000	6.63	0.261	4.78	0.188	1.73	0.068	2.25	H	K	M
LT 023D 01	0.58	0.023	37.29	0.330	9.52	0.375	19.05	0.750	5.18	0.204	3.18	0.125	2.62	0.103	3.25	H	K	K
LT 023D 07	0.58	0.023	37.29	0.330	12.70	0.500	25.40	1.000	7.23	0.285	4.78	0.188	1.90	0.075	2.25	H	K	M
LT 025E 01	0.64	0.025	47.45	0.420	9.52	0.375	19.05	0.750	5.99	0.236	3.56	0.140	2.79	0.110	3.25	H	K	K
LT 025E 07	0.64	0.025	47.45	0.420	12.70	0.500	25.40	1.000	7.93	0.312	5.56	0.219	2.06	0.081	2.25	H	K	M
LT 028E 01	0.71	0.028	62.14	0.550	12.70	0.500	25.40	1.000	6.78	0.267	4.44	0.175	3.18	0.125	3.25	K	M	P
LT 028E 07	0.71	0.028	62.14	0.550	12.70	0.500	25.40	1.000	9.47	0.373	6.35	0.250	2.31	0.091	2.25	M	P	P
LT 030F 01	0.76	0.030	76.83	0.680	12.70	0.500	25.40	1.000	7.75	0.305	5.21	0.205	3.35	0.132	3.25	K	M	P
LT 030F 07	0.76	0.030	76.83	0.680	12.70	0.500	25.40	1.000	10.10	0.398	7.14	0.281	2.48	0.098	2.25	M	P	P
LT 032F 01	0.81	0.032	98.86	0.875	12.70	0.500	25.40	1.000	7.32	0.288	4.57	0.180	3.68	0.145	3.25	K	M	P
LT 032F 07	0.81	0.032	98.86	0.875	12.70	0.500	25.40	1.000	10.21	0.402	7.14	0.281	2.64	0.104	2.25	M	P	P
LT 035G 01	0.89	0.035	120.90	1.070	15.88	0.625	31.75	1.250	8.03	0.316	4.75	0.187	3.89	0.153	3.25	K	M	P
LT 035G 07	0.89	0.035	120.90	1.070	15.88	0.625	31.75	1.250	11.88	0.468	8.74	0.344	2.89	0.114	2.25	M	P	P
LT 038G 01	0.96	0.038	144.62	1.280	15.88	0.625	31.75	1.250	9.80	0.386	6.35	0.250	4.32	0.170	3.25	K	M	P
LT 038G 07	0.96	0.038	144.62	1.280	15.88	0.625	31.75	1.250	13.74	0.541	10.31	0.406	3.14	0.124	2.25	M	P	P
LT 040H 01	1.02	0.040	169.48	1.500	15.88	0.625	31.75	1.250	8.51	0.335	5.38	0.212	5.50	0.220	4.25	K	M	P
LT 040H 07	1.02	0.040	169.48	1.500	12.70	0.500	25.40	1.000	10.28	0.405	7.14	0.281	4.32	0.170	3.25	M	P	P
LT 045H 01	1.14	0.045	242.92	2.150	15.88	0.625	31.75	1.250	9.07	0.357	5.72	0.225	6.22	0.245	4.25	K	M	P
LT 045H 07	1.14	0.045	242.92	2.150	15.88	0.625	31.75	1.250	11.49	0.453	7.95	0.313	4.86	0.191	3.25	M	P	P
LT 048I 01	1.22	0.048	310.70	2.750	15.88	0.625	31.75	1.250	9.86	0.388	5.84	0.230	6.6	0.260	4.25	M	P	P
LT 048I 07	1.22	0.048	310.70	2.750	15.88	0.625	31.75	1.250	11.70	0.460	7.95	0.313	5.18	0.204	3.25	P	R	R
LT 051J 01	1.30	0.051	350.25	3.100	25.40	1.000	50.80	2.000	10.36	0.408	6.35	0.250	6.98	0.275	4.25	M	P	P
LT 051J 07	1.30	0.051	350.25	3.100	15.88	0.625	31.75	1.250	13.14	0.517	9.53	0.375	5.51	0.217	3.25	P	R	R
LT 054K 01	1.37	0.054	395.45	3.500	25.40	1.000	50.80	2.000	12.29	0.484	8.00	0.315	7.49	0.295	4.25	P	R	R
LT 054K 07	1.37	0.054	395.45	3.500	15.88	0.625	31.75	1.250	14.56	0.573	10.31	0.406	5.83	0.230	3.25	R	T	T
LT 059K 01	1.50	0.059	508.44	4.500	25.40	1.000	50.80	2.000	12.67	0.499	7.92	0.312	8.13	0.320	4.25	R	T	T
LT 059K 07	1.50	0.059	508.44	4.500	25.40	1.000	50.80	2.000	16.11	0.634	11.91	0.469	6.37	0.251	3.25	T	V	V
LT 063L 01	1.60	0.063	621.43	5.500	25.40	1.000	50.80	2.000	14.22	0.560	9.52	0.375	8.89	0.350	4.25	T	V	V
LT 063L 07	1.60	0.063	621.43	5.500	25.40	1.000	50.80	2.000	17.15	0.675	11.91	0.469	6.80	0.268	3.25	V	X	X
LT 070M 01	1.78	0.070	847.40	7.500	25.40	1.000	50.80	2.000	15.06	0.593	9.78	0.385	9.53	0.375	4.25	V	X	Z
LT 070M 07	1.78	0.070	847.40	7.500	25.40	1.000	50.80	2.000	19.15	0.754	13.49	0.500	7.62	0.296	3.25	V	X	Z
LT 070M 01	1.78	0.070	847.40	7.500	25.40	1.000	50.80	2.000	16.18	0.637	11.91	0.469	6.80	0.268	3.25	V	X	Z
LT 070M 07	1.78	0.070	847.40	7.500	25.40	1.000	50.80	2.000	20.56	0.811	15.49	0.600	7.62	0.296	3.25	V	X	Z

90°

• Left Hand or Right Helix • Music Wire (Plated), or Stainless Steel (Passivated)

### Price Group

reference to the price list

### Number of Coils

total coils in each spring.

### Body Length

overall length, see sketch below.

### ADDITIONAL INFORMATION

- To translate torque values to direct load: Use  $F = \frac{T}{R}$  Formula  
F = Load applied at Radius R. T = Torque
- To calculate torque values other than those listed (Position of Ends), a direct proportion may be used.
- Inspection of Load. Loads should always be checked at the Radius (R value).
- Direction of Wind. Good design dictates that torsion springs should be used in the direction that winds the coil. When ordering be sure to specify either Left or Right Hand wind.
- Material specifications, finishes and tolerances are detailed on page 163.

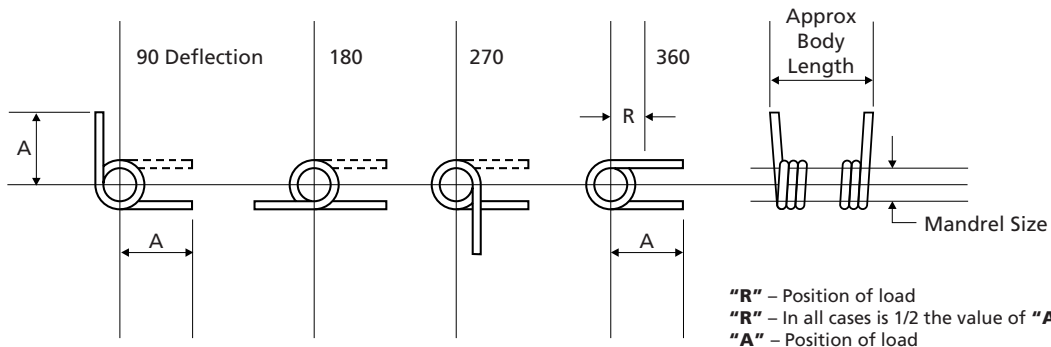

NOTE: The Torsion Springs illustrated above are shown LEFT HAND WOUND

- Please note that the torque listed in the following torsion spring tables relates only to music wire.  
When choosing stainless steel multiply the factors by 0.933.

# TORSION SPRINGS



● Left Hand or Right Helix

● Music Wire (Plated), or Stainless Steel (Passivated)

LEE STOCK NUMBER	NOMINAL WIRE DIAMETER		(T) TORQUE (see footnotes)		(R) RADIUS		(A) LENGTH OF LEG		OUTSIDE DIAMETER		SUGGESTED MANDREL SIZE		(L) BODY LENGTH APPROX.		TOTAL NO. OF COILS	PRICE GROUP	
	MM	IN	N-MM	IN-LB	MM	IN	MM	IN	MM	IN	MM	IN	MM	IN		Music Wire	302 Stainless
LT 012A 01	0.30	0.012	5.65	0.050	4.75	0.187	9.52	0.375	2.67	0.105	1.65	0.065	1.37	0.054	3.25	F	H
LT 012A 07					6.35	0.250	12.70	0.500	3.72	0.146	2.36	0.093	0.99	0.039	2.25	H	K
LT 014A 01	0.36	0.014	8.47	0.075	6.35	0.250	12.70	0.500	3.15	0.124	1.57	0.062	1.65	0.065	3.25	F	H
LT 014A 07					6.35	0.250	12.70	0.500	4.37	0.172	3.18	0.125	1.16	0.046	2.25	H	K
LT 015B 01	0.38	0.015	11.30	0.100	6.35	0.250	12.70	0.500	2.82	0.111	1.57	0.062	1.73	0.068	3.25	H	K
LT 015B 07					6.35	0.250	12.70	0.500	4.35	0.171	2.36	0.093	1.24	0.049	2.25	K	M
LT 017C 01	0.43	0.017	14.12	0.125	6.35	0.250	12.70	0.500	4.06	0.160	2.36	0.093	1.96	0.077	3.25	H	K
LT 017C 07					9.53	0.375	19.05	0.750	5.67	0.223	3.96	0.156	1.40	0.055	2.25	K	M
LT 018C 01	0.46	0.018	16.95	0.150	6.35	0.250	12.70	0.500	4.52	0.178	2.77	0.109	2.03	0.080	3.25	H	K
LT 018C 07					9.53	0.375	19.05	0.750	5.94	0.234	3.96	0.156	1.49	0.059	2.25	K	M
LT 020D 01	0.51	0.020	22.60	0.200	9.52	0.375	19.05	0.750	4.85	0.191	3.05	0.120	2.29	0.090	3.25	H	K
LT 020D 07					12.70	0.500	25.40	1.000	6.78	0.267	4.78	0.188	1.65	0.065	2.25	K	M
LT 021D 01	0.53	0.021	28.25	0.250	9.52	0.375	19.05	0.750	5.08	0.200	3.05	0.120	2.41	0.095	3.25	H	K
LT 021D 07					12.70	0.500	25.40	1.000	6.63	0.261	4.78	0.188	1.73	0.068	2.25	K	M
LT 023D 01	0.58	0.023	37.29	0.330	9.52	0.375	19.05	0.750	5.18	0.204	3.18	0.125	2.62	0.103	3.25	H	K
LT 023D 07					12.70	0.500	25.40	1.000	7.23	0.285	4.78	0.188	1.90	0.075	2.25	K	M
LT 025E 01	0.64	0.025	47.45	0.420	9.52	0.375	19.05	0.750	5.99	0.236	3.56	0.140	2.79	0.110	3.25	H	K
LT 025E 07					12.70	0.500	25.40	1.000	7.93	0.312	5.56	0.219	2.06	0.081	2.25	K	M
LT 028E 01	0.71	0.028	62.14	0.550	12.70	0.500	25.40	1.000	6.78	0.267	4.44	0.175	3.18	0.125	3.25	K	M
LT 028E 07					12.70	0.500	25.40	1.000	9.47	0.373	6.35	0.250	2.31	0.091	2.25	M	P
LT 030F 01	0.76	0.030	76.83	0.680	12.70	0.500	25.40	1.000	7.75	0.305	5.21	0.205	3.35	0.132	3.25	K	M
LT 030F 07					12.70	0.500	25.40	1.000	10.10	0.398	7.14	0.281	2.48	0.098	2.25	M	P
LT 032F 01	0.81	0.032	98.86	0.875	12.70	0.500	25.40	1.000	7.32	0.288	4.57	0.180	3.68	0.145	3.25	K	M
LT 032F 07					12.70	0.500	25.40	1.000	10.21	0.402	7.14	0.281	2.64	0.104	2.25	M	P
LT 035G 01	0.89	0.035	120.90	1.070	15.88	0.625	31.75	1.250	8.03	0.316	4.75	0.187	3.89	0.153	3.25	K	M
LT 035G 07					15.88	0.625	31.75	1.250	11.88	0.468	8.74	0.344	2.89	0.114	2.25	M	P
LT 038G 01	0.96	0.038	144.62	1.280	15.88	0.625	31.75	1.250	9.80	0.386	6.35	0.250	4.32	0.170	3.25	K	M
LT 038G 07					15.88	0.625	31.75	1.250	13.74	0.541	10.31	0.406	3.14	0.124	2.25	M	P
LT 040H 01	1.02	0.040	169.48	1.500	15.88	0.625	31.75	1.250	8.51	0.335	5.38	0.212	5.59	0.220	4.25	K	M
LT 040H 07					12.70	0.500	25.40	1.000	10.28	0.405	7.14	0.281	4.32	0.170	3.25	M	P
LT 045H 01	1.14	0.045	242.92	2.150	15.88	0.625	31.75	1.250	9.07	0.357	5.72	0.225	6.22	0.245	4.25	K	M
LT 045H 07					15.88	0.325	31.75	1.250	11.49	0.453	7.95	0.313	4.86	0.191	3.25	M	P
LT 048J 01	1.22	0.048	310.70	2.750	15.88	0.625	31.75	1.250	9.86	0.388	5.84	0.230	6.6	0.260	4.25	M	P
LT 048J 07					15.88	0.625	31.75	1.250	11.70	0.460	7.95	0.313	5.18	0.204	3.25	P	R
LT 051J 01	1.30	0.051	350.25	3.100	25.40	1.000	50.80	2.000	10.36	0.408	6.35	0.250	6.98	0.275	4.25	M	P
LT 051J 07					15.88	0.625	31.75	1.250	13.14	0.517	9.53	0.375	5.51	0.217	3.25	P	R
LT 054K 01	1.37	0.054	395.45	3.500	25.40	1.000	50.80	2.000	12.29	0.484	8.00	0.315	7.49	0.295	4.25	P	R
LT 054K 07					15.88	0.625	31.75	1.250	14.56	0.573	10.31	0.406	5.83	0.230	3.25	R	T
LT 059K 01	1.50	0.059	508.44	4.500	25.40	1.000	50.80	2.000	12.67	0.499	7.92	0.312	8.13	0.320	4.25	R	T
LT 059K 07					25.40	1.000	50.80	2.000	16.11	0.634	11.91	0.469	6.37	0.251	3.25	T	V
LT 063L 01	1.60	0.063	621.43	5.500	25.40	1.000	50.80	2.000	14.22	0.560	9.52	0.375	8.89	0.350	4.25	T	V
LT 063L 07					25.40	1.000	50.80	2.000	17.15	0.675	11.91	0.469	6.80	0.268	3.25	V	X
LT 070M 01	1.78	0.070	847.40	7.500	25.40	1.000	50.80	2.000	15.06	0.593	9.78	0.385	9.52	0.375	4.25	V	X
LT 070M 07					25.40	1.000	50.80	2.000	19.15	0.754	13.49	0.531	7.56	0.298	3.25	X	Z
LT 075M 01	1.91	0.075	1,039.48	9.200	25.40	1.000	50.80	2.000	16.18	0.637	9.91	0.390	10.21	0.402	4.25	X	Z
LT 075M 07					25.40	1.000	50.80	2.000	20.56	0.810	15.09	0.594	8.10	0.319	3.25	Z	BB
LT 078N 01	1.98	0.078	1,180.71	10.450	25.40	1.000	50.80	2.000	16.69	0.657	10.21	0.402	10.62	0.418	4.25	Z	BB
LT 078N 07					25.40	1.000	50.80	2.000	21.21	0.835	15.09	0.594	8.42	0.332	3.25	BB	BD
LT 085N 01	2.16	0.085	1,453.01	12.860	31.75	1.250	63.50	2.500	19.00	0.748	11.86	0.467	11.56	0.455	4.25	BB	BD
LT 085N 07					31.75	1.250	63.50	2.500	24.19	0.952	17.48	0.688	9.18	0.361	3.25	BD	BF
LT 095P 01	2.41	0.095	1,936.59	17.140	38.10	1.500	76.20	3.000	22.12	0.871	14.07	0.554	12.93	0.509	4.25	BD	BF
LT 095P 07					38.10	1.500	76.20	3.000	28.20	1.110	20.65	0.813	10.26	0.404	3.25	BF	BH
LT 105Q 01	2.67	0.105	2,374.00	21.000	44.45	1.750	88.90	3.500	21.54	0.848	12.70	0.500	16.67	0.656	5.25	BE	BG
LT 105Q 07					44.45	1.750	88.90	3.500	34.08	1.342	26.19	1.031	11.33	0.446	3.25	BF	BH
LT 115R 01	2.92	0.115	3,165.00	28.000	50.80	2.000	101.60	4.000	24.84	0.978	15.09	0.594	18.26	0.719	5.25	BF	BH
LT 115R 07					50.80	2.000	101.60	4.000	36.82	1.450	27.76	1.093	12.41	0.489	3.25	BG	BJ
LT 125S 01	3.18	0.125	3,617.00	32.000	50.80	2.000	101.60	4.000	25.12	0.989	15.01	0.591	23.02	0.906	6.25	BG	BJ
LT 125S 07					50.80	2.000	101.60	4.000	34.84	1.372	26.19	1.031	16.67	0.656	4.25	BH	BK
LT 135T 01	3.43	0.135	4,522.00	40.000	50.80	2.000	101.60	4.000	27.99	1.102	16.92	0.666	24.86	0.979	6.25	BJ	BL
LT 135T 07					50.80	2.000	101.60	4.000	37.89	1.492	28.58	1.125	18.00	0.709	4.25	BK	BM

## ● Left Hand or Right Helix

## ● Music Wire (Plated), or Stainless Steel (Passivated)

LEE STOCK NUMBER	NOMINAL WIRE DIAMETER		(T) TORQUE (see footnotes)		(R) RADIUS		(A) LENGTH OF LEG		OUTSIDE DIAMETER		SUGGESTED MANDREL SIZE		(L) BODY LENGTH APPROX.		TOTAL NO. OF COILS	PRICE GROUP	
	MM	IN	N-MM	IN-LB	MM	IN	MM	IN	MM	IN	MM	IN	MM	IN		Music Wire	302 Stainless
LT 012A 02	0.30	0.012	5.65	0.050	4.75	0.187	9.52	0.375	2.79	0.110	1.70	0.067	2.18	0.086	6.00	F	H
LT 012A 04					6.35	0.250	12.70	0.500	4.24	0.167	2.77	0.109	1.50	0.059	4.00	H	K
LT 014A 02	0.36	0.014	8.47	0.075	6.35	0.250	12.70	0.500	3.38	0.133	1.57	0.062	2.62	0.103	6.00	F	H
LT 014A 04					9.52	0.375	19.05	0.750	4.93	0.194	2.77	0.109	1.90	0.075	4.00	H	K
LT 015B 02	0.38	0.015	11.30	0.100	6.35	0.250	12.70	0.500	3.33	0.131	1.98	0.078	2.72	0.107	6.00	H	K
LT 015B 04					9.52	0.375	19.05	0.750	4.67	0.184	2.77	0.109	1.90	0.075	4.00	K	M
LT 017C 02	0.43	0.017	14.12	0.125	6.35	0.250	12.70	0.500	4.37	0.172	2.67	0.105	3.18	0.125	6.00	H	K
LT 017C 04					9.52	0.375	19.05	0.750	6.32	0.249	4.32	0.170	2.29	0.090	4.00	K	M
LT 018C 02	0.46	0.018	16.95	0.150	6.35	0.250	12.70	0.500	4.19	0.165	2.77	0.109	3.81	0.150	7.00	H	K
LT 018C 04					9.52	0.375	19.05	0.750	5.51	0.217	3.56	0.140	2.77	0.109	5.00	K	M
LT 020D 02	0.51	0.020	22.60	0.200	9.52	0.375	19.05	0.750	4.55	0.179	2.67	0.105	4.19	0.165	7.00	H	K
LT 020D 04					12.70	0.500	25.40	1.000	6.15	0.242	4.06	0.160	3.18	0.125	5.00	K	M
LT 021D 02	0.53	0.021	28.25	0.250	9.52	0.375	19.05	0.750	4.72	0.186	2.77	0.109	4.39	0.173	7.00	H	K
LT 021D 04					12.70	0.500	25.40	1.000	6.30	0.248	3.96	0.156	3.22	0.127	5.00	K	M
LT 023D 02	0.58	0.023	37.29	0.330	9.52	0.375	19.05	0.750	4.85	0.191	2.92	0.115	4.83	0.190	7.00	H	K
LT 023D 04					12.70	0.500	25.40	1.000	6.58	0.259	4.32	0.170	3.68	0.145	5.00	K	M
LT 025E 02	0.64	0.025	47.45	0.420	9.52	0.375	19.05	0.750	5.72	0.225	3.56	0.140	5.23	0.206	7.00	H	K
LT 025E 04					12.70	0.500	25.40	1.000	7.75	0.305	5.16	0.203	3.84	0.151	5.00	K	M
LT 028E 02	0.71	0.028	62.14	0.550	12.70	0.500	25.40	1.000	6.32	0.249	3.96	0.156	5.97	0.235	7.00	K	M
LT 028E 04					12.70	0.500	25.40	1.000	8.64	0.340	5.97	0.235	4.44	0.175	5.00	M	P
LT 030F 02	0.76	0.030	76.83	0.680	12.70	0.500	25.40	1.000	6.93	0.273	4.37	0.172	6.30	0.248	7.00	K	M
LT 030F 04					12.70	0.500	25.40	1.000	10.03	0.395	6.35	0.250	4.60	0.181	5.00	M	P
LT 032F 02	0.81	0.032	98.86	0.875	12.70	0.500	25.40	1.000	6.86	0.270	4.32	0.170	6.73	0.265	7.00	K	M
LT 032F 04					12.70	0.500	25.40	1.000	9.30	0.366	6.35	0.250	5.08	0.200	5.00	M	P
LT 035G 02	0.89	0.035	120.90	1.070	15.88	0.625	31.75	1.250	7.72	0.304	4.75	0.187	7.37	0.290	7.00	K	M
LT 035G 04					15.88	0.625	31.75	1.250	11.46	0.451	7.14	0.281	5.38	0.212	5.00	M	P
LT 038G 02	0.96	0.038	144.62	1.280	15.88	0.625	31.75	1.250	9.22	0.363	6.10	0.240	8.00	0.315	7.00	K	M
LT 038G 04					15.88	0.625	31.75	1.250	12.37	0.487	8.64	0.340	6.04	0.238	5.00	M	P
LT 040H 02	1.02	0.040	169.48	1.500	15.88	0.625	31.75	1.250	8.86	0.349	5.54	0.218	9.50	0.374	8.00	K	M
LT 040H 04					25.40	1.000	50.80	2.000	13.18	0.519	8.71	0.343	6.15	0.242	5.00	M	P
LT 045H 02	1.14	0.045	242.92	2.150	15.88	0.625	31.75	1.250	9.58	0.377	6.10	0.240	10.54	0.415	8.00	K	M
LT 045H 04					25.40	1.000	50.80	2.000	14.60	0.575	9.91	0.390	7.11	0.280	5.00	M	P
LT 048J 02	1.22	0.048	310.70	2.750	15.88	0.625	31.75	1.250	10.29	0.405	6.35	0.250	11.43	0.450	8.00	M	P
LT 048J 04					25.40	1.000	50.80	2.000	15.72	0.619	10.31	0.406	7.42	0.292	5.00	P	R
LT 051J 02	1.30	0.051	350.25	3.100	25.40	1.000	50.80	2.000	10.92	0.430	6.98	0.275	11.94	0.470	8.00	M	P
LT 051J 04					25.40	1.000	50.80	2.000	14.12	0.556	9.52	0.375	9.27	0.365	6.00	P	R
LT 054K 02	1.37	0.054	395.45	3.500	25.40	1.000	50.80	2.000	12.93	0.509	8.76	0.345	12.70	0.500	8.00	P	R
LT 054K 04					25.40	1.000	50.80	2.000	16.61	0.654	11.68	0.460	9.91	0.390	6.00	R	T
LT 059K 02	1.50	0.059	508.44	4.500	25.40	1.000	50.80	2.000	13.36	0.526	8.51	0.335	13.72	0.540	8.00	R	T
LT 059K 04					25.40	1.000	50.80	2.000	17.30	0.681	11.94	0.470	10.80	0.425	6.00	T	V
LT 063L 02	1.60	0.063	621.43	5.500	25.40	1.000	50.80	2.000	15.01	0.591	9.91	0.390	14.73	0.580	8.00	T	V
LT 063L 04					25.40	1.000	50.80	2.000	19.48	0.767	13.89	0.547	11.68	0.460	6.00	V	X
LT 070M 02	1.78	0.070	847.40	7.500	25.40	1.000	50.80	2.000	15.88	0.625	10.31	0.406	16.26	0.640	8.00	V	X
LT 070M 04					25.40	1.000	50.80	2.000	20.57	0.810	14.35	0.565	12.70	0.500	6.00	X	Z
LT 075M 02	1.91	0.075	1,039.48	9.200	25.40	1.000	50.80	2.000	17.07	0.672	10.62	0.418	17.50	0.689	8.00	X	Z
LT 075M 04					25.40	1.000	50.80	2.000	19.23	0.757	12.34	0.486	15.54	0.612	7.00	Z	BB
LT 078N 02	1.98	0.078	1,180.71	10.450	25.40	1.000	50.80	2.000	17.60	0.693	10.95	0.431	18.19	0.716	8.00	Z	BB
LT 078N 04					25.40	1.000	50.80	2.000	19.84	0.781	12.70	0.500	16.15	0.636	7.00	BB	BD
LT 085N 02	2.16	0.085	1,453.01	12.860	31.75	1.250	63.50	2.500	20.07	0.790	12.73	0.501	19.81	0.780	8.00	BB	BD
LT 085N 04					31.75	1.250	63.50	2.500	22.63	0.891	14.73	0.580	17.63	0.694	7.00	BD	BF
LT 095P 02	2.41	0.095	1,936.59	17.140	38.10	1.500	76.20	3.000	23.37	0.920	15.06	0.593	22.15	0.872	8.00	BD	BF
LT 095P 04					38.10	1.500	76.20	3.000	26.37	1.038	17.42	0.686	19.69	0.775	7.00	BF	BH
LT 105Q 02	2.67	0.105	2,374.00	21.000	44.45	1.750	88.90	3.500	24.94	0.982	15.47	0.609	26.67	1.050	9.00	BE	BG
LT 105Q 04					44.45	1.750	88.90	3.500	31.70	1.248	20.65	0.813	21.34	0.840	7.00	BF	BH
LT 115R 02	2.92	0.115	3,165.00	28.000	50.80	2.000	101.60	4.000	26.49	1.043	16.28	0.641	29.21	1.150	9.00	BF	BH
LT 115R 04					50.80	2.000	101.60	4.000	34.24	1.348	21.82	0.859	23.37	0.920	7.00	BG	BJ
LT 125S 02	3.18	0.125	3,617.00	32.000	50.80	2.000	101.60	4.000	27.48	1.082	16.92	0.666	38.10	1.500	11.00	BG	BJ
LT 125S 04					50.80	2.000	101.60	4.000	34.44	1.356	22.48	0.885	28.58	1.125	8.00	BH	BK
LT 135T 02	3.43	0.135	4,522.00	40.000	50.80	2.000	101.60	4.000	30.20	1.189	18.67	0.735	41.15	1.620	11.00	BJ	BL
LT 135T 04					50.80	2.000	101.60	4.000	37.87	1.491	24.82	0.977	30.86	1.215	8.00	BK	BM

Torque shown relates only to music wire. When using stainless steel, multiply by 0.933.

# TORSION SPRINGS



● Left Hand or Right Helix

● Music Wire (Plated), or Stainless Steel (Passivated)

LEE STOCK NUMBER	NOMINAL WIRE DIAMETER		(T) TORQUE (see footnotes)		(R) RADIUS		(A) LENGTH OF LEG		OUTSIDE DIAMETER		SUGGESTED MANDREL SIZE		(L) BODY LENGTH APPROX.		TOTAL NO. OF COILS	PRICE GROUP	
	MM	IN	N-MM	IN-LB	MM	IN	MM	IN	MM	IN	MM	IN	MM	IN		M	S
LT 012A 03	0.30	0.012	5.65	0.050	4.75	0.187	9.52	0.375	2.62	0.103	1.57	0.062	3.53	0.139	9.75	F	H
LT 012A 05					6.35	0.250	12.70	0.500	4.34	0.171	2.77	0.109	2.18	0.086	5.75	H	K
LT 014A 03	0.36	0.014	8.47	0.075	6.35	0.250	12.70	0.500	3.15	0.124	1.57	0.062	3.96	0.156	9.75	F	H
LT 014A 05					9.52	0.375	19.05	0.750	5.10	0.201	2.77	0.109	2.54	0.100	5.75	H	K
LT 015B 03	0.38	0.015	11.30	0.100	6.35	0.250	12.70	0.500	3.18	0.125	1.98	0.078	4.39	0.173	9.75	H	K
LT 015B 05					9.52	0.375	19.05	0.750	5.08	0.200	2.77	0.109	2.72	0.107	5.75	K	M
LT 017C 03	0.43	0.017	14.12	0.125	6.35	0.250	12.70	0.500	4.06	0.160	2.36	0.093	4.78	0.188	9.75	H	K
LT 017C 05					9.52	0.375	19.05	0.750	6.58	0.259	4.44	0.175	3.05	0.120	5.75	K	M
LT 018C 03	0.46	0.018	16.95	0.150	6.35	0.250	12.70	0.500	4.06	0.160	2.77	0.109	5.79	0.228	10.75	H	K
LT 018C 05					9.52	0.375	19.05	0.750	6.25	0.246	3.96	0.156	3.81	0.150	6.75	K	M
LT 020D 03	0.51	0.020	22.60	0.200	9.52	0.375	19.05	0.750	4.44	0.175	2.67	0.105	6.10	0.240	10.75	H	K
LT 020D 05					12.70	0.500	25.40	1.000	6.81	0.268	4.75	0.187	4.06	0.160	6.75	K	M
LT 021D 03	0.53	0.021	28.25	0.250	9.52	0.375	19.05	0.750	4.70	0.185	2.77	0.109	6.76	0.266	10.75	H	K
LT 021D 05					12.70	0.500	25.40	1.000	6.25	0.246	3.76	0.148	4.95	0.195	7.75	K	M
LT 023D 03	0.58	0.023	37.29	0.330	9.52	0.375	19.05	0.750	4.75	0.187	2.77	0.109	7.11	0.280	10.75	H	K
LT 023D 05					12.70	0.500	25.40	1.000	6.38	0.251	4.11	0.162	5.33	0.210	7.75	K	M
LT 025E 03	0.64	0.025	47.45	0.420	9.52	0.375	19.05	0.750	5.59	0.220	3.56	0.140	7.75	0.304	10.75	H	K
LT 025E 05					12.70	0.500	25.40	1.000	8.66	0.341	5.54	0.218	5.23	0.206	6.75	K	M
LT 028E 03	0.71	0.028	62.14	0.550	12.70	0.500	25.40	1.000	6.22	0.245	3.96	0.156	8.64	0.340	10.75	K	M
LT 028E 05					12.70	0.500	25.40	1.000	8.36	0.329	5.72	0.225	6.48	0.255	7.75	M	P
LT 030F 03	0.76	0.030	76.83	0.680	12.70	0.500	25.40	1.000	6.88	0.271	4.37	0.172	9.27	0.365	10.75	K	M
LT 030F 05					12.70	0.500	25.40	1.000	9.58	0.377	6.35	0.250	7.11	0.280	7.75	M	P
LT 032F 03	0.81	0.032	98.86	0.875	12.70	0.500	25.40	1.000	6.70	0.264	4.11	0.162	9.78	0.385	10.75	K	M
LT 032F 05					12.70	0.500	25.40	1.000	8.99	0.354	6.10	0.240	7.37	0.290	7.75	M	P
LT 035G 03	0.89	0.035	120.90	1.070	15.88	0.625	31.75	1.250	7.92	0.312	4.75	0.187	10.80	0.425	10.75	K	M
LT 035G 05					15.88	0.625	31.75	1.250	11.07	0.436	7.14	0.281	8.00	0.315	7.75	M	P
LT 038G 03	1.02	0.040	144.62	1.280	15.88	0.625	31.75	1.250	8.97	0.353	5.84	0.230	11.56	0.455	10.75	K	M
LT 038G 05					15.88	0.625	31.75	1.250	12.12	0.477	8.38	0.330	8.69	0.342	7.75	M	P
LT 040H 03	1.02	0.040	169.48	1.500	15.88	0.625	31.75	1.250	9.12	0.359	5.54	0.218	13.34	0.525	11.75	K	M
LT 040H 05					25.40	1.000	50.80	2.000	13.00	0.512	8.71	0.343	9.14	0.360	7.75	M	P
LT 045H 03	1.14	0.045	242.92	2.150	15.88	0.625	31.75	1.250	9.70	0.382	6.10	0.240	14.86	0.585	11.75	K	M
LT 045H 05					25.40	1.000	50.80	2.000	14.12	0.556	9.53	0.375	10.29	0.405	7.75	M	P
LT 048J 03	1.22	0.048	310.70	2.750	15.88	0.625	31.75	1.250	10.59	0.417	6.35	0.250	16.00	0.630	11.75	M	P
LT 048J 05					25.40	1.000	50.80	2.000	15.26	0.601	10.31	0.406	11.05	0.435	7.75	P	R
LT 051J 03	1.30	0.051	350.25	3.100	25.40	1.000	50.80	2.000	11.15	0.439	7.11	0.280	16.76	0.660	11.75	M	P
LT 051J 05					25.40	1.000	50.80	2.000	14.50	0.571	9.91	0.390	12.95	0.510	8.75	P	R
LT 054K 03	1.37	0.054	395.45	3.500	25.40	1.000	50.80	2.000	13.06	0.514	8.76	0.345	17.78	0.700	11.75	P	R
LT 054K 05					25.40	1.000	50.80	2.000	16.86	0.664	12.06	0.475	13.72	0.540	8.75	R	T
LT 059K 03	1.50	0.059	508.44	4.500	25.40	1.000	50.80	2.000	13.64	0.537	8.89	0.350	19.43	0.765	11.75	R	T
LT 059K 05					25.40	1.000	50.80	2.000	17.75	0.699	12.32	0.485	14.86	0.585	8.75	T	V
LT 063L 03	1.52	0.060	621.43	5.500	25.40	1.000	50.80	2.000	15.24	0.600	10.31	0.406	20.83	0.820	11.75	T	V
LT 063L 05					25.40	1.000	50.80	2.000	19.91	0.784	14.27	0.562	16.00	0.630	8.75	V	X
LT 070M 03	1.78	0.070	847.40	7.500	25.40	1.000	50.80	2.000	16.23	0.639	10.67	0.420	20.45	0.805	11.75	V	X
LT 070M 05					25.40	1.000	50.80	2.000	20.98	0.826	14.73	0.580	17.78	0.700	8.75	X	Z
LT 075M 03	1.91	0.075	1,039.48	9.200	25.40	1.000	50.80	2.000	17.40	0.685	12.50	0.492	24.77	0.975	11.75	X	Z
LT 075M 05					25.40	1.000	50.80	2.000	20.57	0.810	13.39	0.527	20.88	0.822	9.75	Z	BB
LT 078N 03	1.98	0.078	1,180.71	10.450	25.40	1.000	50.80	2.000	17.93	0.706	12.88	0.507	25.76	1.014	11.75	Z	BB
LT 078N 05					25.40	1.000	50.80	2.000	21.21	0.835	13.79	0.543	21.72	0.855	9.75	BB	BD
LT 085N 03	2.16	0.085	1,453.01	12.860	31.75	1.250	63.50	2.500	20.45	0.805	14.83	0.584	28.07	1.105	11.75	BB	BD
LT 085N 05					31.75	1.250	63.50	2.500	24.21	0.953	15.98	0.629	23.67	0.932	9.75	BD	BF
LT 095P 03	2.41	0.095	1,936.59	17.140	38.10	1.500	76.20	3.000	23.80	0.937	17.48	0.688	31.37	1.235	11.75	BD	BF
LT 095P 05					38.10	1.500	76.20	3.000	28.19	1.110	18.87	0.743	26.47	1.042	9.75	BF	BH
LT 105Q 03	2.67	0.105	2,374.00	21.000	44.45	1.750	88.90	3.500	27.69	1.090	17.86	0.703	34.00	1.339	11.75	BE	BG
LT 105Q 05					44.45	1.750	88.90	3.500	34.09	1.342	22.63	0.891	28.67	1.129	9.75	BF	BH
LT 115R 03	2.92	0.115	3,165.00	28.000	50.80	2.000	101.60	4.000	27.58	1.086	17.48	0.688	43.08	1.696	13.75	BF	BH
LT 115R 05					50.80	2.000	101.60	4.000	36.45	1.435	23.83	0.938	31.40	1.236	9.75	BG	BJ
LT 125S 03	3.18	0.125	3,617.00	32.000	50.80	2.000	101.60	4.000	30.20	1.189	19.08	0.751	50.01	1.969	14.75	BG	BJ
LT 125S 05					50.80	2.000	101.60	4.000	38.51	1.516	25.73	1.013	40.48	1.594	11.75	BH	BK
LT 135T 03	3.43	0.135	4,522.00	40.000	50.80	2.000	101.60	4.000	33.05	1.301	20.96	0.825	54.01	2.126	14.75	BJ	BL
LT 135T 05					50.80	2.000	101.60	4.000	42.16	1.660	28.24	1.112	43.72	1.721	11.75	BK	BM

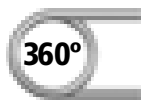

# TORSION SPRINGS

● Left Hand or Right Helix

● Music Wire (Plated), or Stainless Steel (Passivated)

LEE STOCK NUMBER	NOMINAL WIRE DIAMETER		(T) TORQUE (see footnotes)		(R) RADIUS		(A) LENGTH OF LEG		OUTSIDE DIAMETER		SUGGESTED MANDREL SIZE		(L) BODY LENGTH APPROX.		TOTAL NO. OF COILS	PRICE GROUP	
	MM	IN	N-MM	IN-LB	MM	IN	MM	IN	MM	IN	MM	IN	MM	IN		Music Wire	302 Stainless
																M	S
LT 012A 06	0.30	0.012	5.65	0.050	6.35	0.250	12.70	0.500	4.42	0.174	2.77	0.109	2.84	0.112	7.50	H	K
LT 012A 08					9.53	0.375	19.05	0.750	5.62	0.221	3.97	0.156	1.98	0.078	5.50	H	K
LT 014A 06	0.36	0.014	8.47	0.075	9.52	0.375	19.05	0.750	5.18	0.204	2.77	0.109	3.15	0.124	7.50	H	K
LT 014A 08					9.53	0.375	19.05	0.750	6.93	0.273	4.76	0.188	2.31	0.091	5.50	H	K
LT 015B 06	0.38	0.015	11.30	0.100	9.52	0.375	19.05	0.750	5.28	0.208	2.77	0.109	3.35	0.132	7.50	K	M
LT 015B 08					12.70	0.500	25.40	1.000	6.88	0.271	4.76	0.188	2.48	0.098	5.50	K	M
LT 017C 06	0.43	0.017	14.12	0.125	9.52	0.375	19.05	0.750	5.97	0.235	3.96	0.156	4.24	0.167	8.50	K	M
LT 017C 08					12.70	0.500	25.40	1.000	7.68	0.303	5.56	0.219	3.24	0.128	6.50	K	M
LT 018C 06	0.46	0.018	16.95	0.150	9.52	0.375	19.05	0.750	5.94	0.234	3.96	0.156	5.08	0.200	9.50	K	M
LT 018C 08					12.70	0.500	25.40	1.000	9.43	0.371	6.75	0.266	2.97	0.117	5.50	L	N
LT 020D 06	0.51	0.020	22.60	0.200	12.70	0.500	25.40	1.000	6.45	0.254	4.37	0.172	5.46	0.215	9.50	K	M
LT 020D 08					15.88	0.625	31.75	1.250	10.77	0.424	7.94	0.313	3.30	0.130	5.50	L	N
LT 021D 06	0.53	0.021	28.25	0.250	12.70	0.500	25.40	1.000	6.91	0.272	4.75	0.187	5.84	0.230	9.50	K	M
LT 021D 08					12.70	0.500	25.40	1.000	10.51	0.414	7.54	0.297	3.47	0.137	5.50	L	N
LT 023D 06	0.58	0.023	37.29	0.330	12.70	0.500	25.40	1.000	6.88	0.271	4.57	0.180	6.35	0.250	9.50	K	M
LT 023D 08					15.88	0.625	31.75	1.250	11.46	0.451	8.33	0.328	3.80	0.150	5.50	L	N
LT 025E 06	0.64	0.025	47.45	0.420	12.70	0.500	25.40	1.000	8.26	0.325	5.54	0.218	6.98	0.275	9.50	K	M
LT 025E 08					15.88	0.625	31.75	1.250	12.57	0.495	9.13	0.359	4.13	0.163	5.50	K	M
LT 028E 06	0.71	0.028	62.14	0.550	12.70	0.500	25.40	1.000	9.02	0.355	6.22	0.245	7.75	0.305	9.50	M	P
LT 028E 08					25.40	1.000	50.80	2.000	15.05	0.592	11.11	0.438	4.62	0.182	5.50	N	Q
LT 030F 06	0.76	0.030	76.83	0.680	12.70	0.500	25.40	1.000	10.41	0.410	6.35	0.250	8.26	0.325	9.50	M	P
LT 030F 08					25.40	1.000	50.80	2.000	16.04	0.632	11.51	0.453	4.95	0.195	5.50	N	Q
LT 032F 06	0.81	0.032	98.86	0.875	12.70	0.500	25.40	1.000	9.70	0.382	6.35	0.250	8.76	0.345	9.50	M	P
LT 032F 08					25.40	1.000	50.80	2.000	16.19	0.637	11.91	0.469	5.28	0.208	5.50	N	Q
LT 035G 06	0.89	0.035	120.90	1.070	15.88	0.625	31.75	1.250	11.99	0.472	7.92	0.312	9.65	0.380	9.50	M	P
LT 035G 08					25.40	1.000	50.80	2.000	18.88	0.743	13.89	0.547	5.78	0.228	5.50	N	Q
LT 038G 06	1.02	0.040	144.62	1.280	15.88	0.625	31.75	1.250	13.06	0.514	9.02	0.355	10.41	0.410	9.50	M	P
LT 038G 08					25.40	1.000	50.80	2.000	26.67	1.050	20.24	0.797	6.60	0.260	5.50	N	Q
LT 040H 06	1.02	0.040	169.48	1.500	25.40	1.000	50.80	2.000	12.90	0.508	8.71	0.343	11.94	0.470	10.50	M	P
LT 040H 08					25.40	1.000	50.80	2.000	17.07	0.672	12.70	0.500	8.64	0.340	7.50	N	Q
LT 045H 06	1.14	0.045	242.92	2.150	25.40	1.000	50.80	2.000	13.94	0.549	9.53	0.375	13.46	0.530	10.50	M	P
LT 045H 08					25.40	1.000	50.80	2.000	19.09	0.751	14.29	0.563	9.72	0.383	7.50	N	Q
LT 048J 06	1.22	0.048	310.70	2.750	25.40	1.000	50.80	2.000	15.11	0.595	10.31	0.406	14.48	0.570	10.50	P	R
LT 048J 08					25.40	1.000	50.80	2.000	19.38	0.763	14.29	0.563	10.36	0.408	7.50	Q	S
LT 051J 06	1.30	0.051	350.25	3.100	25.40	1.000	50.80	2.000	15.95	0.628	11.10	0.437	15.24	0.600	10.50	P	R
LT 051J 08					25.40	1.000	50.80	2.000	21.83	0.859	16.27	0.641	11.01	0.434	7.50	Q	S
LT 054K 06	1.37	0.054	395.45	3.500	25.40	1.000	50.80	2.000	17.63	0.694	12.70	0.500	17.53	0.690	11.50	R	T
LT 054K 08					25.40	1.000	50.80	2.000	21.54	0.848	16.27	0.641	13.03	0.513	8.50	S	U
LT 059K 06	1.50	0.059	508.44	4.500	25.40	1.000	50.80	2.000	18.01	0.709	12.45	0.490	19.05	0.750	11.50	T	V
LT 059K 08					25.40	1.000	50.80	2.000	23.85	0.939	17.86	0.703	14.24	0.561	8.50	U	W
LT 063L 06	1.52	0.060	621.43	5.500	25.40	1.000	50.80	2.000	20.27	0.798	14.68	0.578	20.45	0.805	11.50	V	X
LT 063L 08					25.40	1.000	50.80	2.000	21.08	0.830	15.48	0.609	14.48	0.570	8.50	W	Y
LT 070M 06	1.78	0.070	847.40	7.500	25.40	1.000	50.80	2.000	21.41	0.843	15.06	0.593	22.61	0.890	11.50	X	Z
LT 070M 08					38.10	1.500	76.20	3.000	28.35	1.116	21.43	0.844	16.89	0.665	8.50	Y	BA
LT 075M 06	1.91	0.075	1,039.48	9.200	25.40	1.000	50.80	2.000	25.02	0.985	16.76	0.660	22.35	0.880	10.50	Z	BB
LT 075M 08					44.45	1.750	88.90	3.500	34.25	1.348	25.80	1.016	16.19	0.638	7.50	BA	BC
LT 078N 06	1.98	0.078	1,180.71	10.450	25.40	1.000	50.80	2.000	25.78	1.015	17.27	0.680	23.24	0.915	10.50	BB	BD
LT 078N 08					44.45	1.750	88.90	3.500	35.30	1.390	26.59	1.047	16.84	0.663	7.50	BC	BE
LT 085N 06	2.16	0.085	1,453.01	12.860	31.75	1.250	63.50	2.500	27.08	1.066	18.19	0.716	27.53	1.084	11.50	BD	BF
LT 085N 08					50.80	2.000	101.60	4.000	35.85	1.412	27.38	1.078	20.51	0.808	8.50	BE	BF
LT 095P 06	2.41	0.095	1,936.59	17.140	38.10	1.500	76.20	3.000	31.57	1.243	21.46	0.845	30.76	1.211	11.50	BF	BH
LT 095P 08					50.80	2.000	101.60	4.000	41.86	1.648	31.75	1.250	22.92	0.903	8.50	BG	BJ
LT 105Q 06	2.67	0.105	2,374.00	21.000	44.45	1.750	88.90	3.500	34.77	1.369	23.01	0.906	36.00	1.418	12.50	BF	BH
LT 105Q 08					50.80	2.000	101.60	4.000	45.65	1.797	34.93	1.375	28.00	1.103	9.50	BG	BJ
LT 115R 06	2.92	0.115	3,165.00	28.000	50.80	2.000	101.60	4.000	37.21	1.465	24.61	0.969	39.43	1.553	12.50	BG	BJ
LT 115R 08					50.80	2.000	101.60	4.000	49.31	1.941	37.70	1.484	30.67	1.208	9.50	BH	BK
LT 125S 06	3.18	0.125	3,617.00	32.000	50.80	2.000	101.60	4.000	40.77	1.605	27.53	1.084	49.21	1.938	14.50	BH	BK
LT 125S 08					50.80	2.000	101.60	4.000	49.98	1.968	38.50	1.516	39.69	1.563	11.50	BJ	BL
LT 135T 06	3.43	0.135	4,522.00	40.000	50.80	2.000	101.60	4.000	44.58	1.755	30.18	1.188	53.15	2.093	14.50	BK	BM
LT 135T 08					53.98	2.125	107.95	4.250	54.37	2.141	42.07	1.656	42.86	1.688	11.50	BL	BP

Torque shown relates only to music wire. When using stainless steel, multiply by 0.933.