



CUSTOM SPRINGS

Lee Spring Company manufactures custom battery springs, as well as stamped and four-slide contacts to match your specifications.

Custom Battery Springs can be configured to meet custom specifications and materials. When designing Battery Springs, determine the contact location based on the American National Standards Institute (ANSI) and International Electrotechnical Commission (IEC) standard dimensions. Reference should be made to ANSI Standard C18 and IEC Standard IEC86.

Designs can be accommodated for a wide range of Battery sizes, beyond the commonly specified AA, AAA, C and D sizes.

Comprehensive Capabilities

Configurations:

- Interior Mount • Exterior Mount • Double Mount

Materials:

- Nickel Plated Carbon Steel • Beryllium Copper
- Silver Plated Beryllium Copper • Phosphor Bronze
- Stainless Steel 17-7, 301, 302 and 316

SPRING TYPE (I)

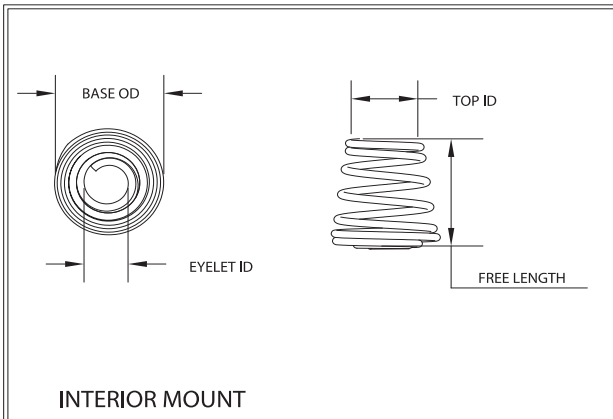

SPRING TYPE (II)

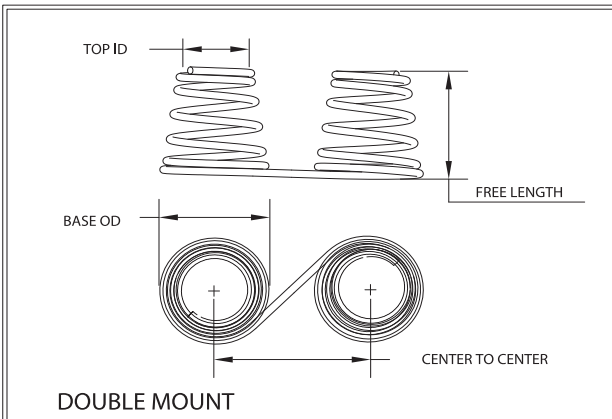

SPRING TYPE (III)

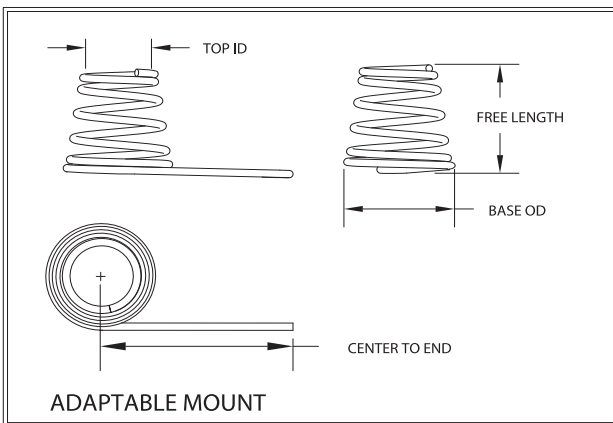

SPRING TYPE (IV)

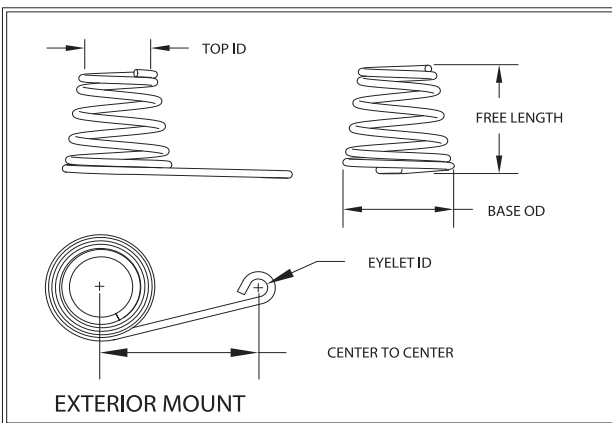

INDICATE UNITS OF MEASURE (IN. & LB.), (MM & KG)

1. **SPRING TYPE** I II III IV
2. **BATTERY TYPE** AA AAA C D
3. **MATERIAL** _____
4. **WIRE DIAMETER** _____
5. **BASE OD** _____ +/- _____
6. **TOP ID** _____ +/- _____
7. **FREE LENGTH** _____ +/- _____
8. **CENTER TO CENTER/END** _____ +/- _____
9. **EYELET ID** _____ +/- _____
10. **NUMBER OF ACTIVE COILS** _____
11. **TOTAL NUMBER OF COILS** _____
12. **APPROX. LOAD** _____ @ _____
13. **FINISH** _____

COMPANY: _____

ADDRESS: _____

CITY: _____

STATE: _____ ZIP: _____

CONTACT: _____

PHONE: _____

FAX: _____

EMAIL: _____

QUANTITIES TO BE QUOTED: _____

END USE OR APPLICATION: _____
